

## RÁMY S VNĚJŠÍM ÚCHYTEM PRO PARAPETY

SYSTÉMY: COR 70 INDUSTRIAL, COR 80 INDUSTRIAL A COR 70 SKRYTÉ KŘÍDLO CC16

DATUM: 27/11/2014

STRANA Č.: 025/14

P991408

**JIŽ K DISPOZICI**

Představujeme 5 nových ráků s úchytem na parapety pro sérii Cor 70 Industrial, Cor 80 Industrial a Cor 70 Skryté křídlo CC16.

Na vystřihnutí otvorů pro vnější rohovník je třeba odstranit obrubu úchytu ráků.



COR 70 INDUSTRIAL	
REFERENCE	POPIS
COR-7956	RÁM OKNA S VNĚJŠÍM ÚCHYTEM PRO PARAPETY
COR-7957	RÁMOKNA HI S VNĚJŠÍM ÚCHYTEM NA PARAPETY

COR 80 INDUSTRIAL	
REFERENCE	POPIS
COR-7756	RÁM OKNA S VNĚJŠÍM ÚCHYTEM PRO PARAPETY
COR-7757	RÁMOKNA HI S VNĚJŠÍM ÚCHYTEM PRO PARAPETY

COR 70 SKRYTÉ KŘÍDLO CC16	
REFERENCE	POPIS
770560	RÁM OKNA S VNĚJŠÍM ÚCHYTEM PRO PARAPETY

Představujeme také nový 100 mm naklipovací parapet (Reference Cor-2817).



# COR 70 INDUSTRIAL

Perfiles a escala

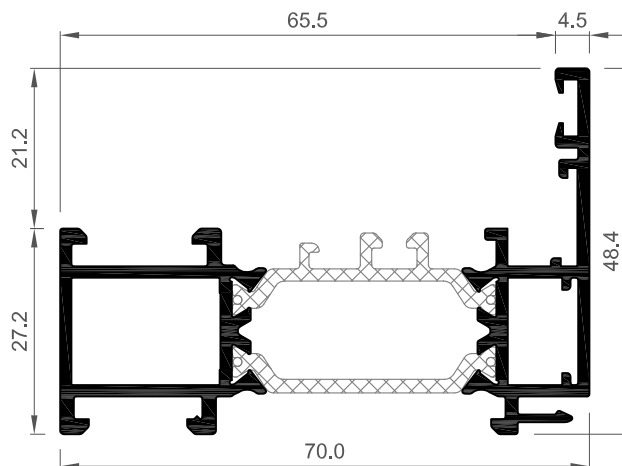

<b>COR-7956</b>	Marco ventana con enganche			
Peso (gr/m)	1.287,50			
Superficie (dm <sup>2</sup> /m)	48,87			
Inercia (cm <sup>4</sup> )	Ixx	4,95	Iyy	26,37
Esc. Principal	347922			
Esc. Secundaria	327920			
Esc. Alineamiento	296838			

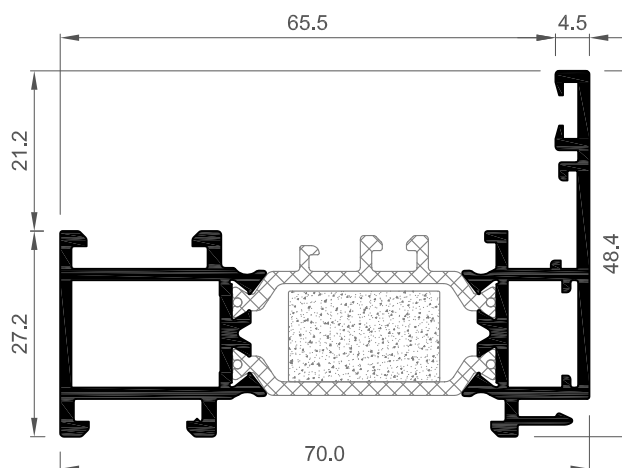

<b>COR-7957</b>	Marco ventana con enganche HI			
Peso (gr/m)	1.287,50			
Superficie (dm <sup>2</sup> /m)	48,87			
Inercia (cm <sup>4</sup> )	Ixx	4,95	Iyy	26,37
Esc. Principal	347922			
Esc. Secundaria	327920			
Esc. Alineamiento	296838			

# COR 80 INDUSTRIAL

Perfiles a escala

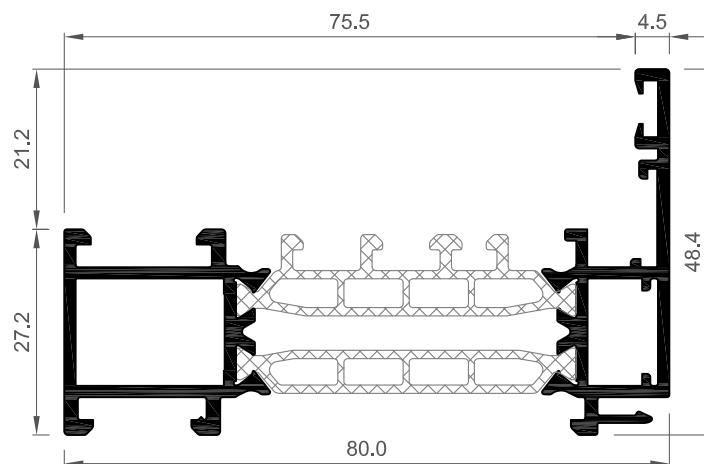

<b>COR-7756</b>	Marco ventana con enganche			
Peso (gr/m)	1.612,50			
Superficie (dm <sup>2</sup> /m)	48,87			
Inercia (cm <sup>4</sup> )	Ixx	4,95	Iyy	36,87
Esc. Principal	347922			
Esc. Secundaria	327920			
Esc. Alineamiento	296838			

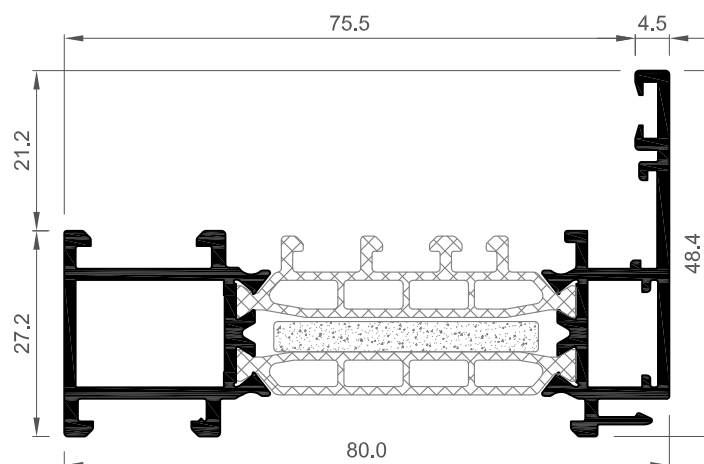

<b>COR-7757</b>	Marco ventana con enganche HI			
Peso (gr/m)	1.612,50			
Superficie (dm <sup>2</sup> /m)	48,87			
Inercia (cm <sup>4</sup> )	Ixx	4,95	Iyy	36,87
Esc. Principal	347922			
Esc. Secundaria	327920			
Esc. Alineamiento	296838			

# COR 70 HO CC16

Perfiles a escala

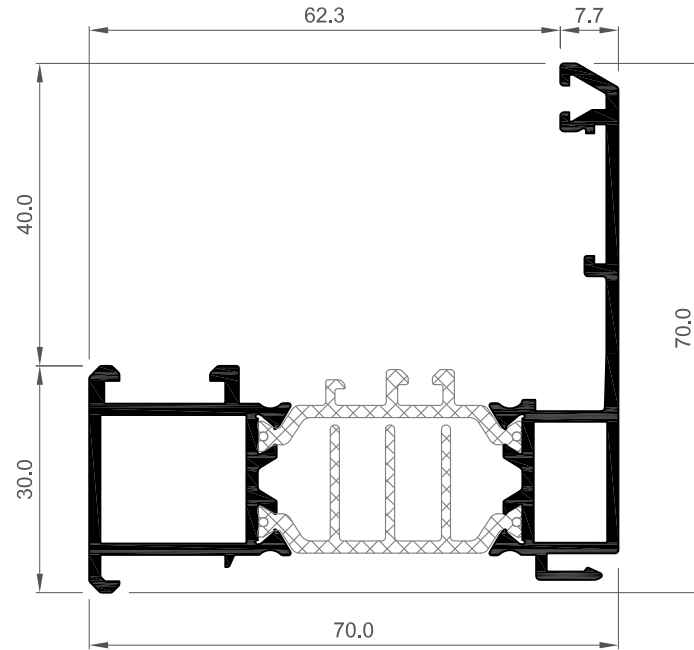

<b>770560</b>	Marco con enganche Cor 70 HO CC16			
Peso (gr/m)	1.500,40			
Superficie (dm <sup>2</sup> /m)	52,41			
Inercia (cm <sup>4</sup> )	Ixx	13,29	Iyy	29,31
Esc. Principal	247230			
Esc. Secundaria	246830			
Esc. Alineamiento	287310			

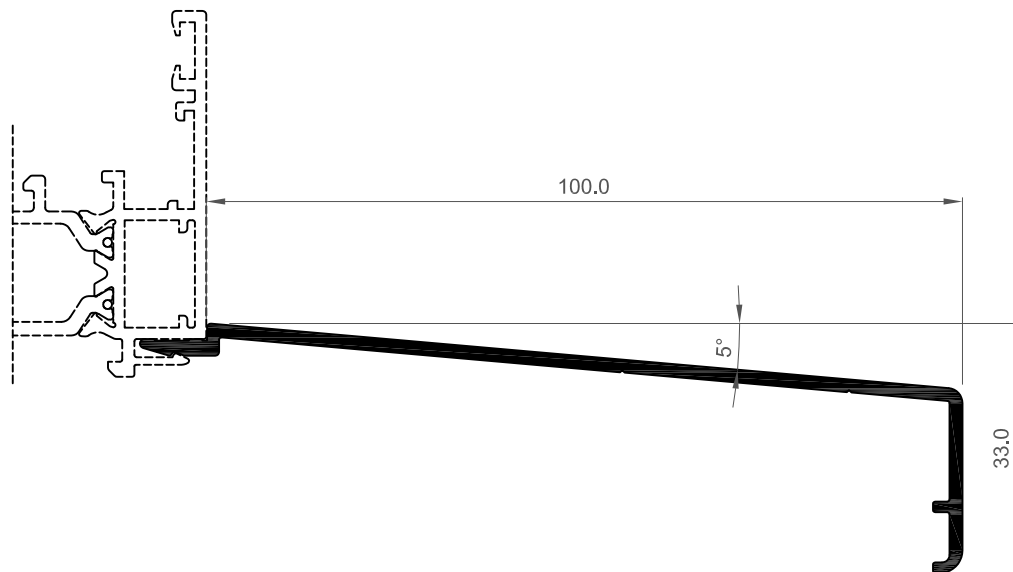

<b>COR-2817</b>	Alargadera con enganche de 100 mm			
Peso (gr/m)	626,40			
Superficie (dm <sup>2</sup> /m)	27,69			
Inercia (cm <sup>4</sup> )	Ixx	1,34	Iyy	29,29

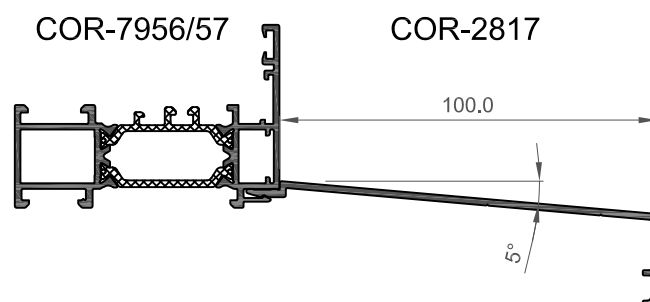
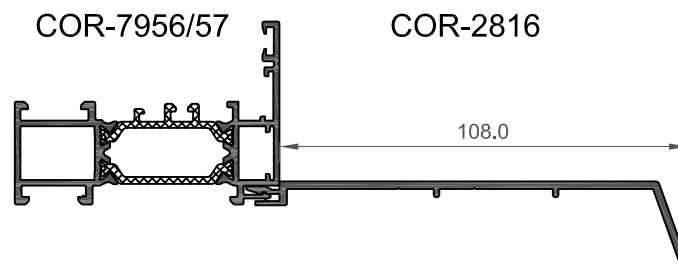
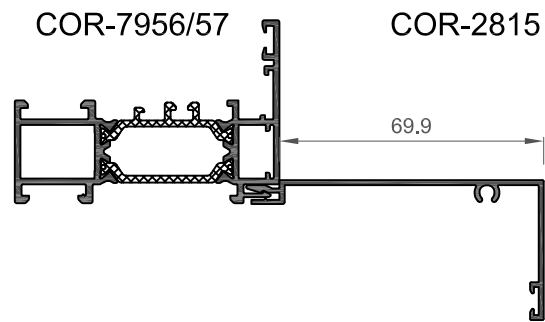

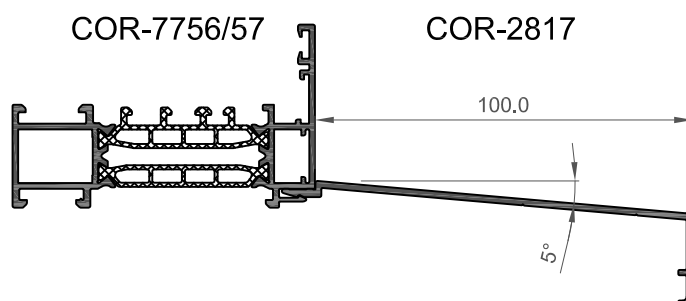
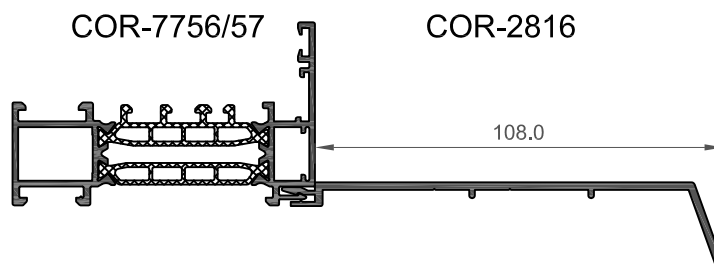
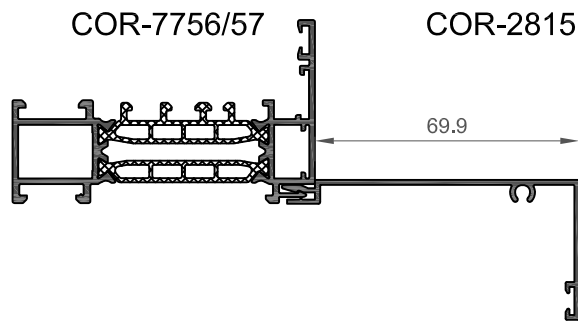



# COR 70 HO CC16

Detalles de fabricación

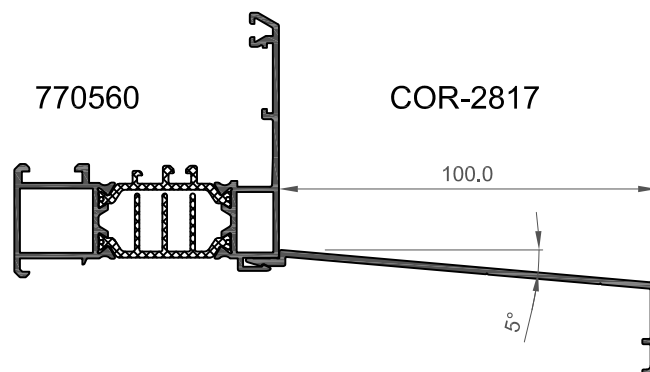
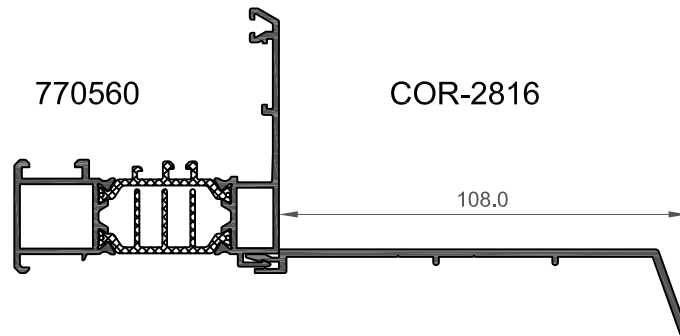
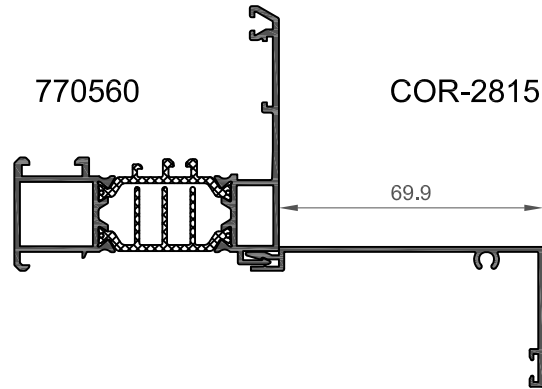

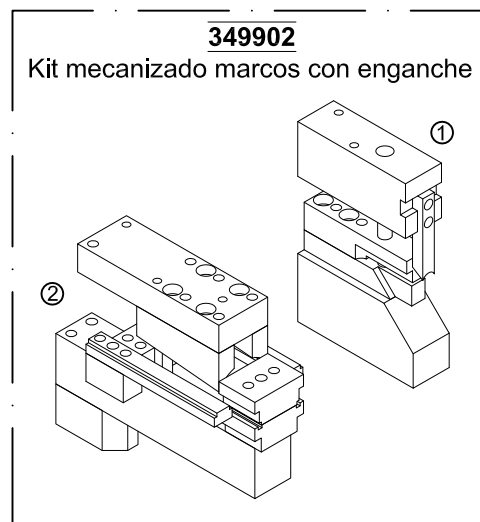
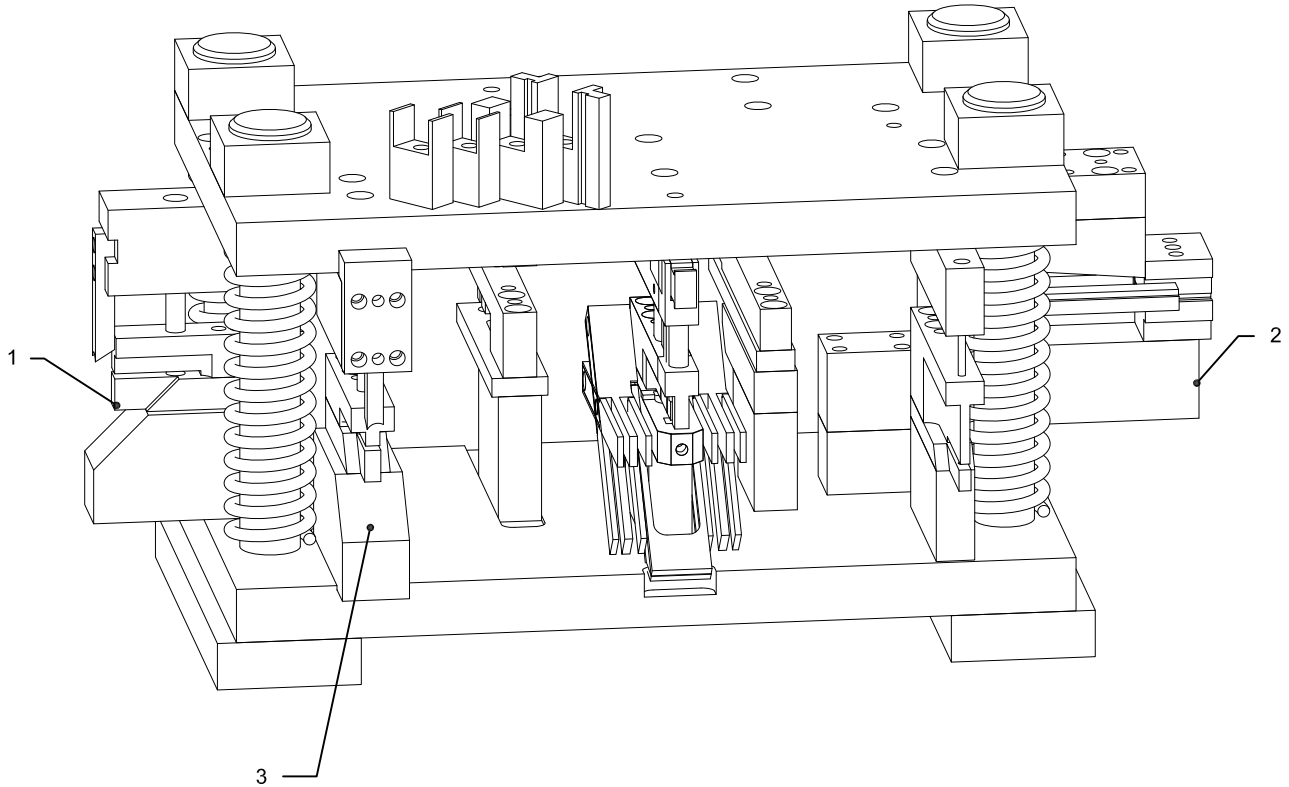

Para troquelar las escuadras de los marcos con enganche es necesario instalar el kit **349902** en cualquiera de los troqueles de escuadras (347798, 347799, 347998 o 347999)

E = 1:2

## OPERACIÓN 1: Mecanizado escuadra principal tetón cuadrado

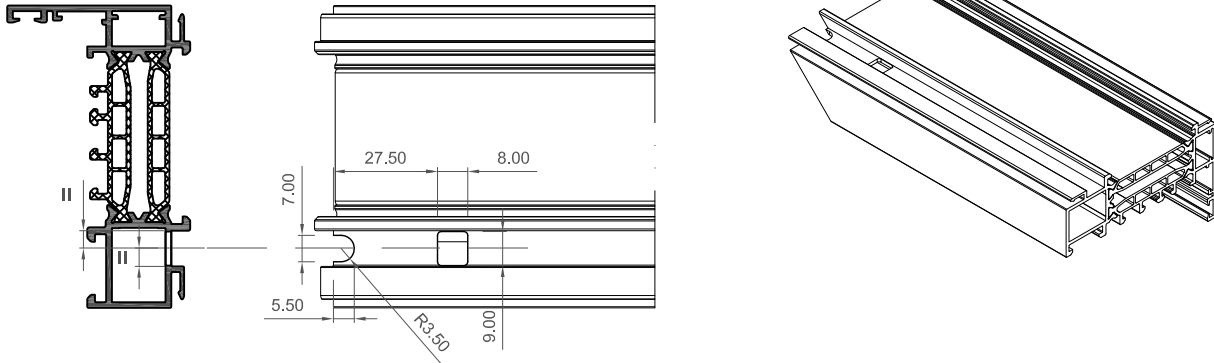

## OPERACIÓN 2: Barrido pestañas exteriores marcos

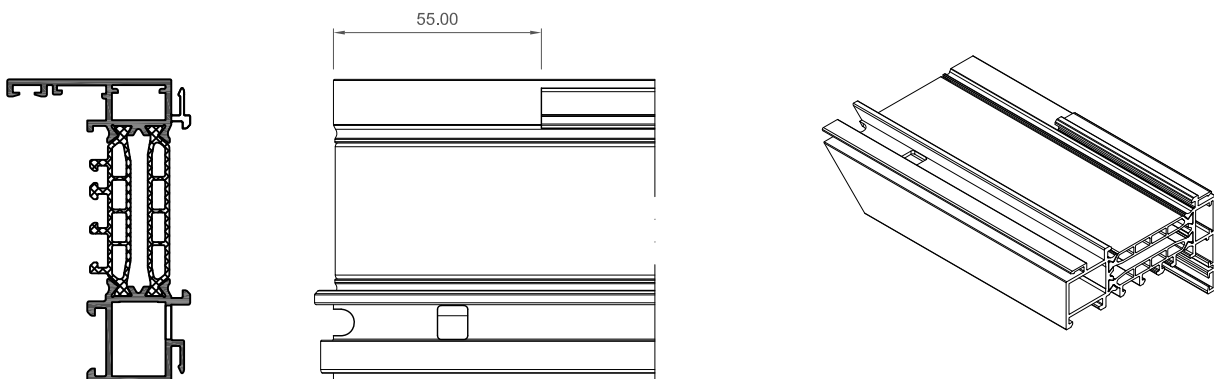

## OPERACIÓN 3: Mecanizado escuadra secundaria de tetón cuadrado

